

Model No.: TC7FD00-04
 Product Line: Tymphany

Rev: 1
 Last Update: 2017-04-25 14:32:09

Product Description

This TC family 2.5 inch 4 ohm full-range driver, with ferrite magnet, paper cone and rubber surround, and steel basket, is designed to be a cost-effective high performance full range driver. The cone utilizes Tymphany-patented PentaCut NRSC cone technology to help dampen and control cone resonances, optimizing the listening experience. The motor contains a copper cap to lower inductance and distortion. The product was designed with portable and other compact applications in mind.



Mechanical Drawing

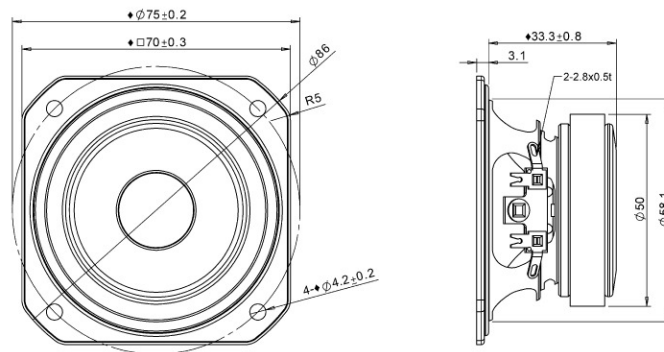

Specifications

DC Resistance	Revc	Ohms	3.22	5.0%	Energy Bandwidth Product	EBP	(1/Qes)*fs
Minimum Impedance	Zmin	Ohms	3.95	7.5%	Moving Mass	Mms	g
Voice Coil Inductance	Le	mH	0.02		Suspension Compliance	Cms	um/N
Resonant Frequency	Fs	Hz	143.42	15%	Effective Cone diameter	D	cm
Mechanical Q Factor	Qms		3.66		Effective Piston Area	Sd	cm ²
Electrical Q Factor	Qes	1.22			Effective Volume	Vas	L
Total Q Factor	Qts	0.92			Motor Force Factor	BL	Tm
Ratio Fs/Qts	F	Fs/Qts	156.4		Motor Efficiency Factor	β	(T*M ²)/Ohms
Half Space Sensitivity @2.83V	db@2.83V/1M	dB	86.36	+/- 1.0db	Voice coil former Material	VCfm	ASV
Half Space Sensitivity @1W/1M	db@1W/1M	dB	83.3	+/- 1.0db	Voice coil inner diameter	VCd	mm
Gap Height	Gh	mm	3		Rated Noise Power	P	W
Maximum Linear Excursion	Xmax	mm	1		Test Spectrum Bandwidth		130Hz - 20kHz
Ferrofluid Type	FF				Driver Size	Inch	2.5 in
Driver Mass	Kg	0.18					

Frequency and Impedance Response

