

# F SERIES

# W3-2141

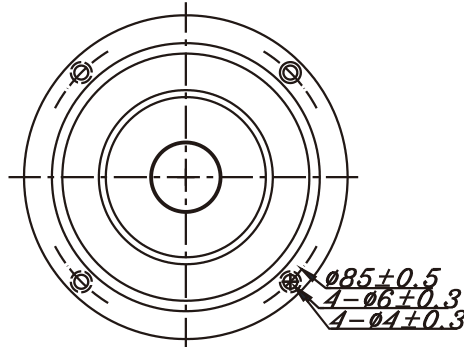
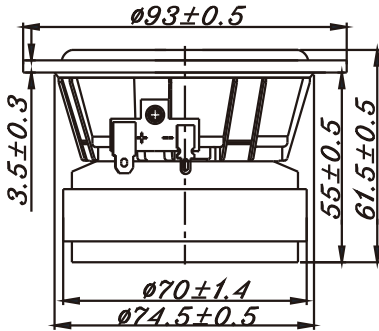

- FULL RANGE DESIGN
- UNDERHUNG MOTOR DESIGN WITH FERRITE MAGNET,  $X_{max} = 1.6\text{mm}$
- VERY LOW THD (2<sup>nd</sup> AND 3<sup>rd</sup> HARMONIC DISTORTION)
- UNIQUE PHASE PLUG FOR BETTER DISPERSION
- BAMBOO FIBER PAPER CONE WITH DURABLE STRUCTURED SANTOPRENE SURROUND

## 3" PAPER FULL RANGE

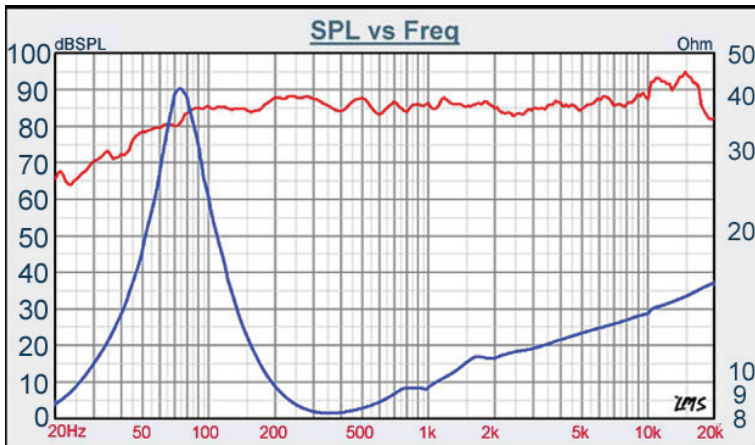

DIAPHRAGM MTL	Paper
SURROUND MTL	Structured Santoprene
NOMINAL IMPEDANCE	8 $\Omega$
DCR IMPEDANCE	6.5 $\Omega$
SENSITIVITY 1W/1m	87 dB
FREQUENCY RESPONSE	75 - 20K Hz
FREE AIR RESONANCE	75 Hz
VOICE COIL DIAMETER	20.4 mm
AIR GAP HEIGHT	8 mm
RATED POWER INPUT	25 W
MAXIMUM POWER INPUT	50 W
FORCE FACTOR, BL	3.64 TM
TYPE OF MAGNET	Ferrite
MOVING MASS	1.996 g
FERROFLUID ENHANCED	No
SUSPENSION COMPLIANCE	2269 $\mu\text{MN}^{-1}$
EFFECTIVE PISTON AREA	0.0032 $\text{M}^2$
Levc	0.020 mH
Zo	40 $\Omega$
X-max	1.6 mm
Vas	3.30 Litr
Qts	0.39
Qms	2.51
Qes	0.46

**TB** SPEAKERS

VOICE: 886.2.26570282 FAX: 886.2.26580166  
E-MAIL: info@tb-speaker.com